

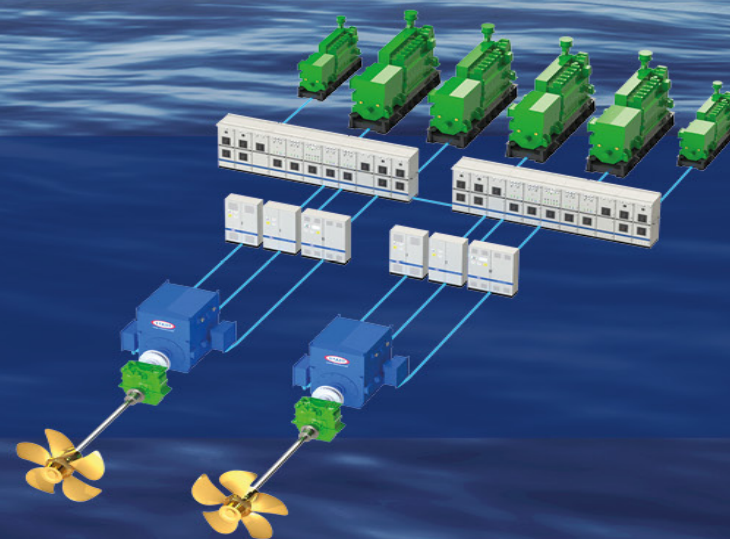

LEAN PROPULSION



**SIMPLY THE BEST SOLUTION
FOR ANY NAVAL SHIP**



STADT - AWARDED TECHNOLOGY LEADER

The STADT Group was founded by Hallvard L. Slettevoll in 1985. We are located in the new and modern STADT Maritime Center in Gjerdsвика harbour.

For many years STADT has been a leading company in AC drive innovations. Long experience from development of motor drives has resulted in the patented STADT Lean Drive technology. This has huge advantages compared to traditional PWM-technology, since it is free from electric disturbances. The STADT Lean Drive is also a very efficient



power drive system, bringing reliability up to a new standard.

The first STADT electric propulsion delivery went to the Norwegian coastguard K/V Tromsø in 1996, representing a technological breakthrough.



The Lean Drive was patented in 2008, and launched to the first ship applications the same year. The new drive technology has been awarded several times for its unique characteristics, and many ships are now sailing with the Lean Drive technology all over the world.

STADT - YOUR SYSTEM INTEGRATOR

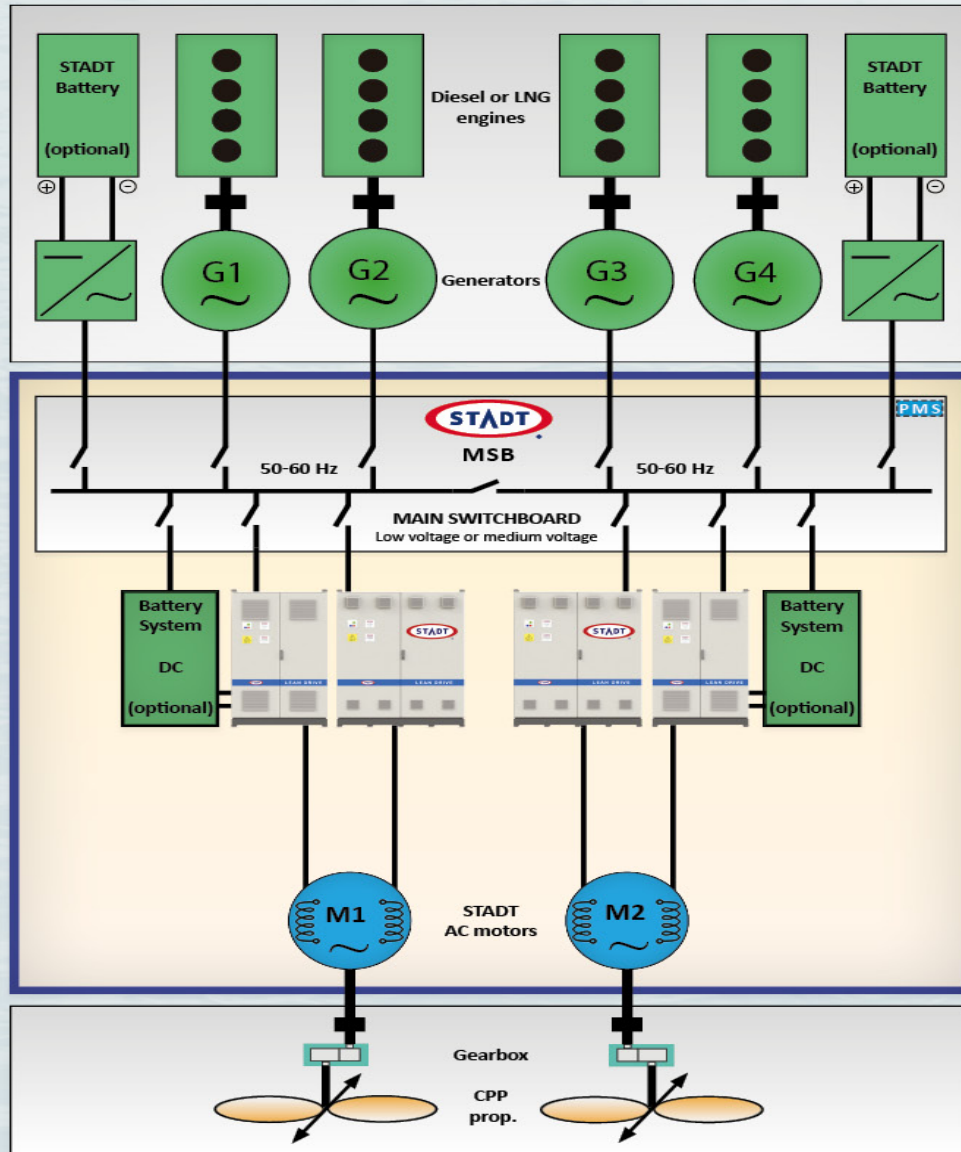

**LET US DESIGN YOUR NEW
SUSTAINABLE PROPULSION
SOLUTION**

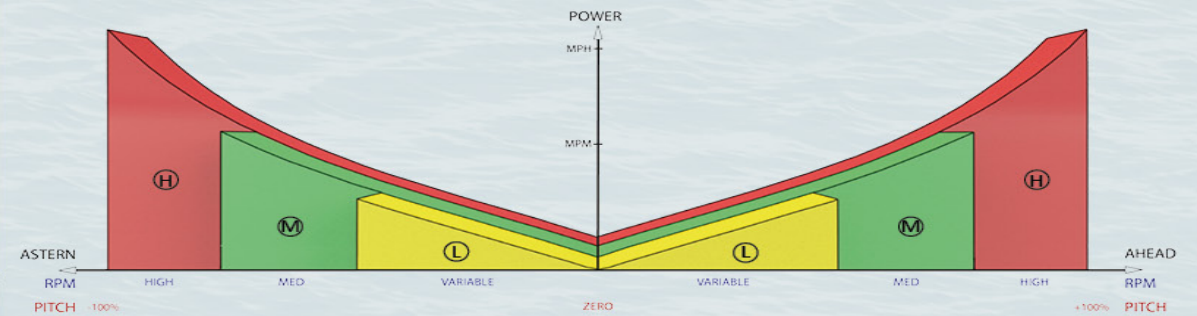

THE STADT SCOPE

Built according to MIL-STD-901 standard, we offer a full product range as listed below.



STADT Lean Drives. Scalable in power up to 50 MW per propeller.



STADT AC motors, a broad range.



STADT main switchboards, MCC, low voltage and medium voltage.

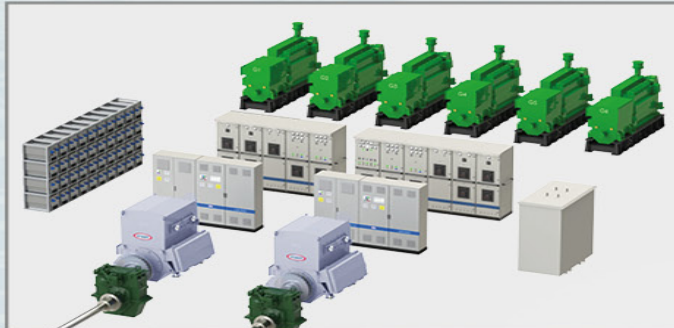

STADT power generators, battery systems, shore-to-ship power solutions, distribution transformers, etc.



Power Management System(PMS), IAS, remote access from shore, Dynamic Positioning(DP).

SERVICES and EPC:

- Engineering of propulsion solutions
- Manufacturing and installation
- Commissioning
- Global Services

STADT HISTORY

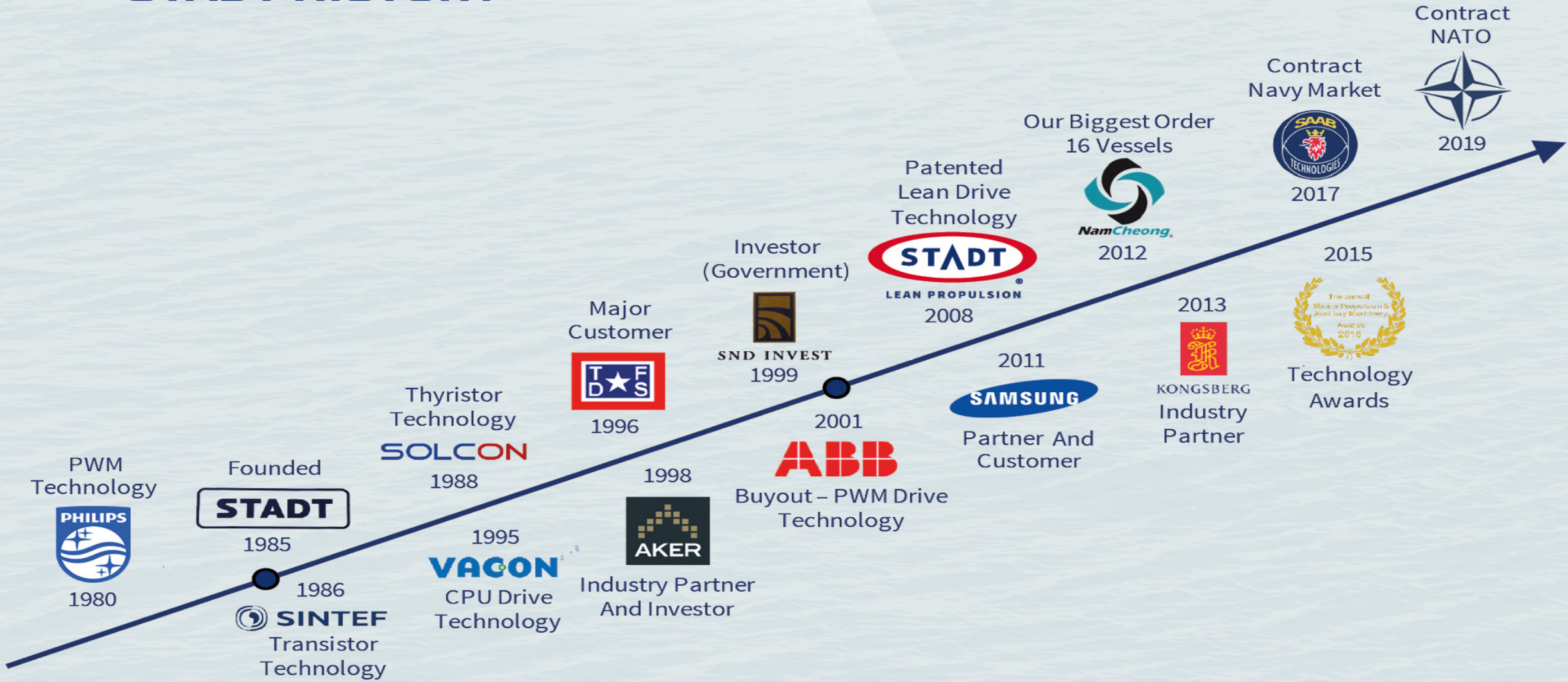

30 YEARS IN AC DRIVE DEVELOPEMENT



®

LEAN PROPULSION

www.stadt.no

STEALTH AND SAFE PROPULSION

No electromagnetic interference, EMI, due to sine wave operation

No acoustic switching noises

No harmonic voltage distortion, THD, on the ship

No transformers for the propulsion are needed

No electric losses in the drives at normal operation

High redundancy in all levels of the drive systems

Major reduction of space and weight for the drives

Minimal need for cooling of drives and its systems

No need for screened power cables and cable segregation

Rugged and very well proven technologies

MTBF and lifetime improved dramatically compared to competitors

Simplified technology , 80 % reduction in number of components

COMPLETE SILENCE



STADT LEAN PROPULSION - PATENTED TECHNOLOGY

Superior technology with Stealth performance. Ensures that the propeller never stops.

SUSTAINABLE, LEAN AND GREEN:

- Reduced fuel consumption, by slow steaming
- Only 6 % losses in systems (AC Motors and alternators included.)
- Reduced NOx, SOx, BC and CO2 emission
- Reduced maintenance and high redundancy



LEAN DRIVE FOR ANY SIZE OF NAVAL SHIPS

TECHNOLOGY DIFFERENCES

STADT LEAN DRIVE TECHNOLOGY



STEALTH

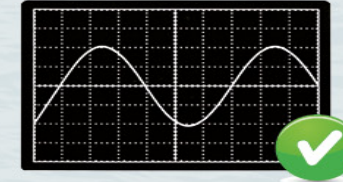

SINE WAVE IS NOISE FREE,
NO EMI

COMPETITOR PWM DRIVE TECHNOLOGY

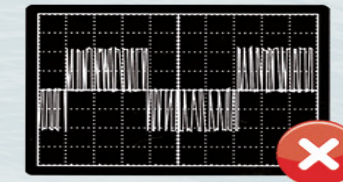
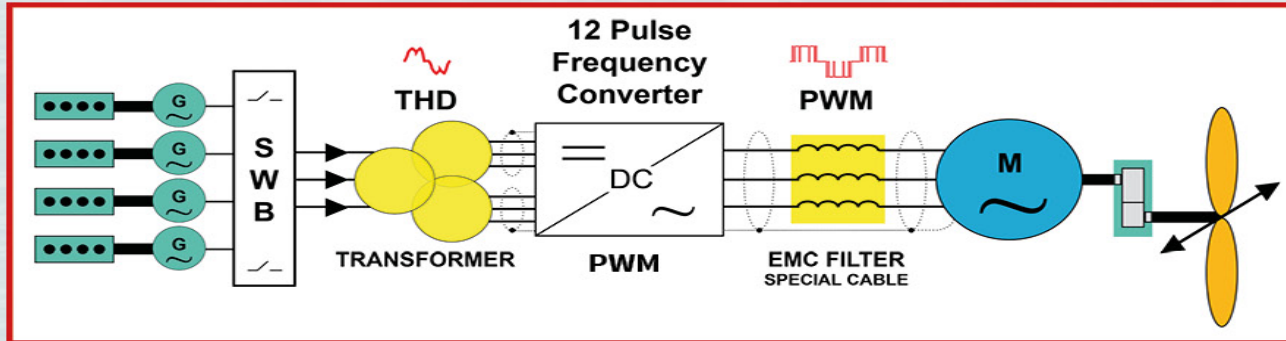

PWM CREATES A LOT
OF EMI AND ACOUSTIC
SWITCHING NOISE

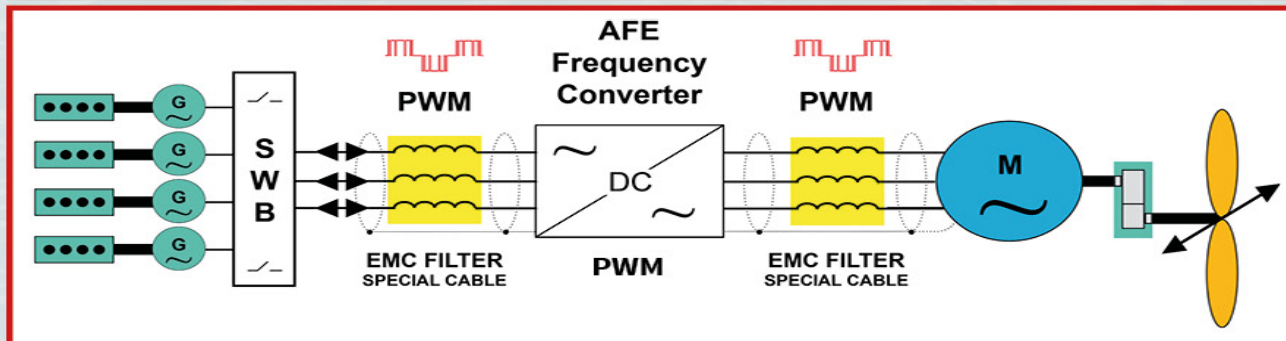

EVALUATION OF TODAY'S DIFFERENT DRIVE SOLUTIONS

| Lean Issues To Consider | STADT Lean Drive | 12 Pulse or 24 Pulse | AFE (Active Front End) |
|---|--------------------------|-----------------------------|-------------------------------|
| Technology in AC drive | Sine Wave | PWM | PWM |
| No. of electric energy transformations | 0 | 4 | 4 or 5 |
| Power Train Losses | No, (negligible) | 6 % | 6 - 7 % |
| Cooling Type | Air is sufficient | Water | Water |
| Power Transformers Needed | No | Yes | Sometimes• - - - |
| Redundant Power Units | Standard | Special | Special |
| Harmonic Distortion (THD) | No | High | High |
| Electromagnetic Interference | No | High | High |
| Acoustic Switching Noise | No | Yes | Yes |
| Screened Power Cables needed | No | Yes | Yes |
| Depending on Harmonic Filters | No | Yes | Yes |
| Designed Economic Lifetime | 30 Years | 6 Years | 6 Years |
| Maintenance Requirement | Very Low | Frequent | Frequent |
| Onboard Crew Skills | Ordinary | Special | Special |
| MTBF (mean time between failures) | 7 Years | 1 Year | 1 Year |
| MTTR (mean time to repair) | 1 Hour | 1 Week | 1 Week |
| Spares Globally Available | Yes | No | No |
| Weight of Drive System | 100 % | 1100 % - 1400 % | 600 % - 1600 % |
| Size of Drive System | 100 % | 500 % - 600 % | 450 % - 700 % |
| All Voltage Class (220V-15kV) | Yes | No | No |
| Power Scalable | Yes | No | No |
| Regenerates Power to Grid | Yes | No | Yes |
| No. of Power Components in Line | 1 | 80 000 | 150 000 |
| Capacitors In Main Power Circuit | No | Yes | Yes |
| Explosion Risk in Drive | No | Yes | Yes |
| Propeller Pitch Configuration | CP | CP or FP | CP or FP |
| Financial Risk (Service cost, Off-hire) | Very Low | High | High |

THE DIFFERENCE:

STADT LEAN DRIVE -PATENTED-

COMPLEX PWM DRIVE

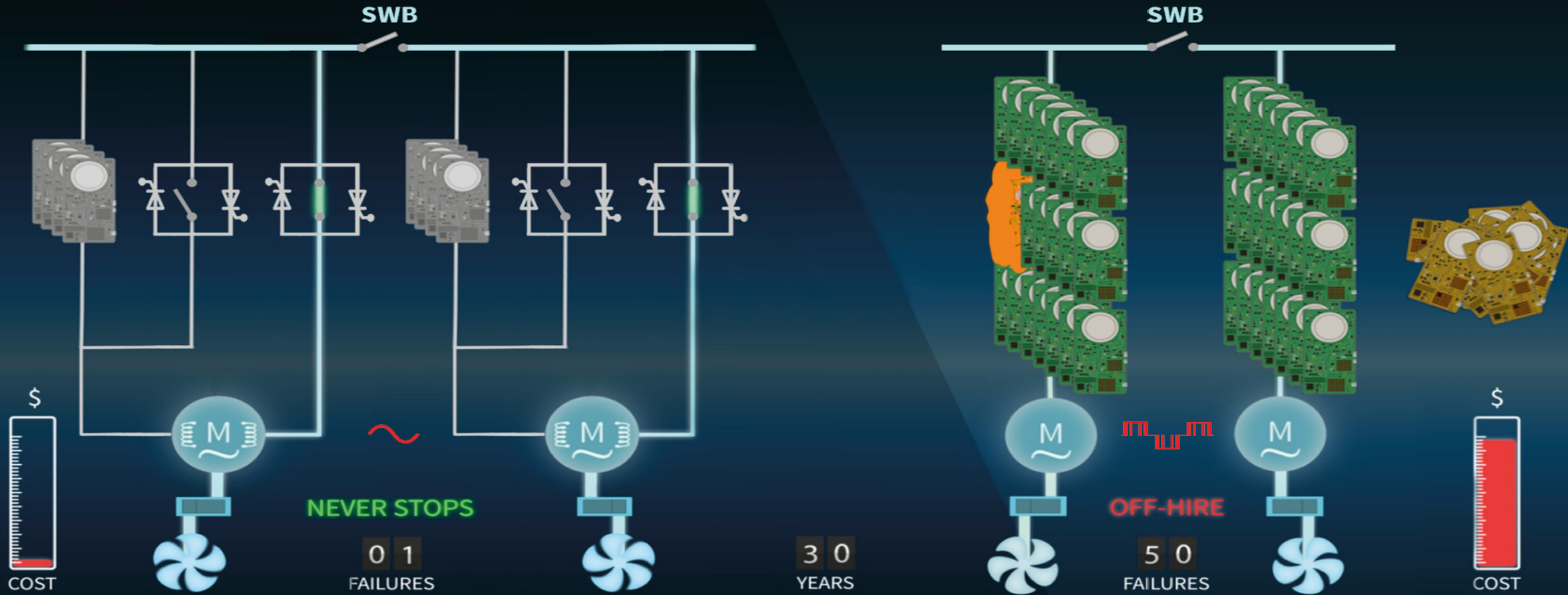

See our animated film at www.STADT.no

COMPLEX PWM DRIVES

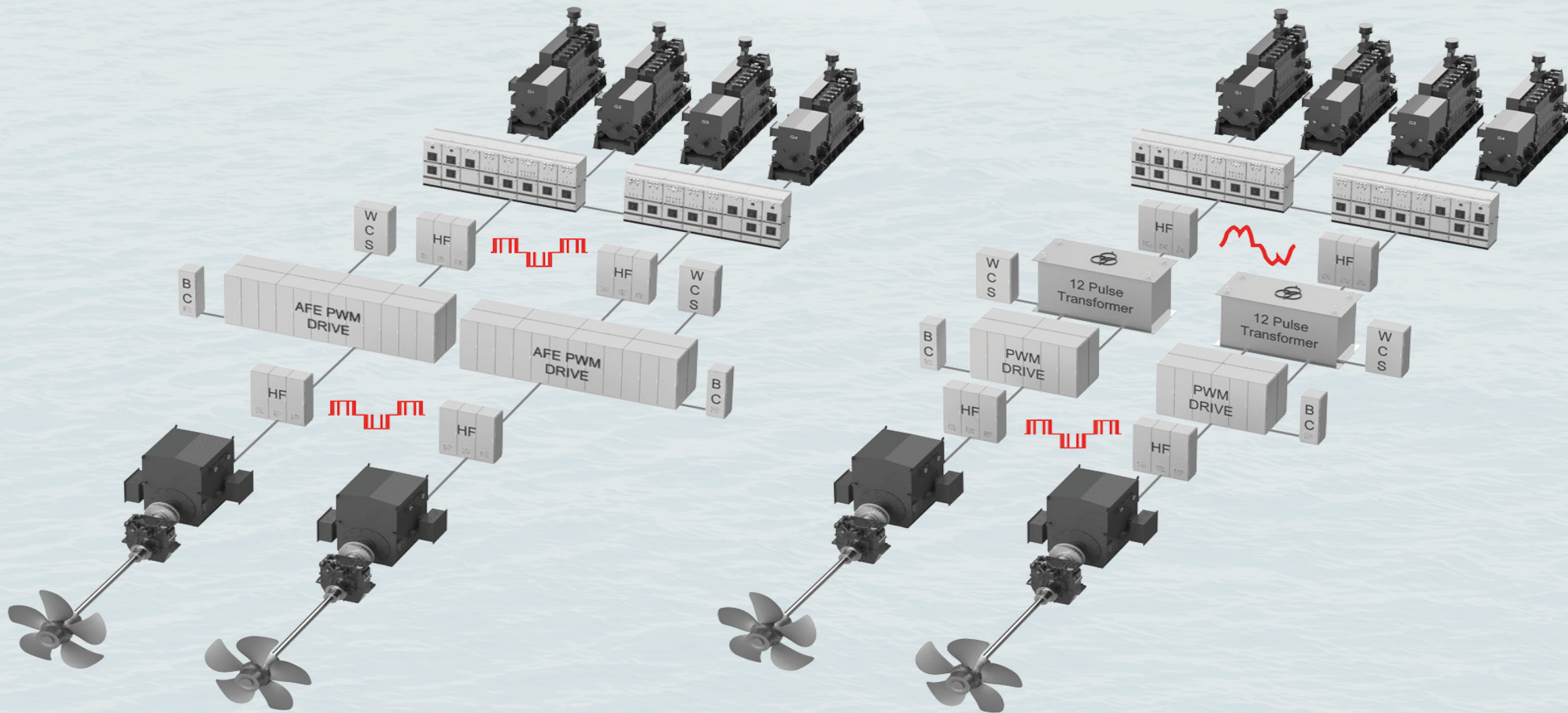

AFE PWM

12 OR 24 PULSE PWM

DISCOVER THE POWER OF SIMPLICITY

ELIMINATED:

- POWER DISTURBANCE THD ON GRID
- HARMONIC FILTERS
- 12 P - 24 P TRANSFORMER
- NOISE (PWM>EMC)
- EXPLOSION RISK (CAPACITORS)
- 80.000 COMPONENTS
- COOLING SYSTEMS
- 5-6 % WASTED HEAT
- COMPLEXITY

= **LESS OFF-HIRE**

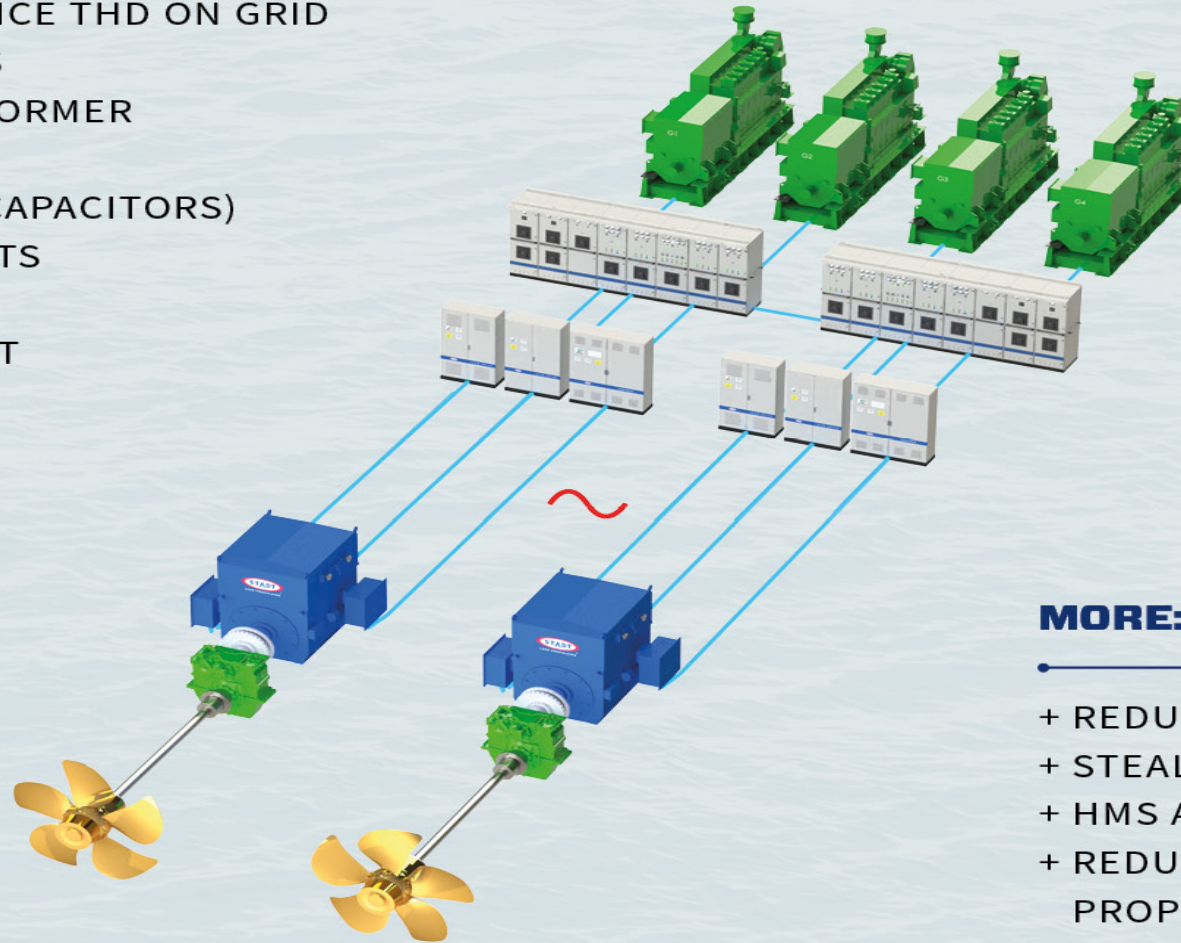

STADT LEAN DRIVE

MORE:

- + REDUNDANCY IN DRIVE
- + STEALTH
- + HMS AND COMFORT (SILENCE)
- + REDUNDANCY, ALSO IN AC PROPULSION MOTORS
- + POWER TO PROPELLER

= **BETTER PERFORMANCE**

STADT LEAN PROPULSION REFERENCES



ILLUSTRATION ONLY

1 Vessel

SAAB AB - Sweden

Naval ship



NATO contract

Naval ship



ILLUSTRATION ONLY

1 Vessel



1 Vessel

MV "Sanco Spirit"

SRV operated by PGS



1 Vessel

MV "Sanco Star"
SRV operated by PGS



4 Vessels

**"THOR Magni", "Modi",
"Frigg", "Freyja"**
SSV operated by PGS



1 Vessel

MV "Econuri"
Incheon Port Authority Guide Ship
Samsung Heavy Industries

150 MW INSTALLED POWER



14 Vessels

“SC Winter”, “SC Bongkot”,
“Warami”, “SK 901” - “SK 912”
AHTSV NCA80E, Nam Cheong

“TOPAZ Master”
“TOPAZ Mariner”
NCA80E for Topaz Marine



2 Vessels



1 Vessel

MY “White Rabbit”
Trimaran yacht 83x20m
Echo Yard Australia

MV “Ocean Fortune”
MV “Ocean Mermaid”
SSV - Vestland Offshore



2 Vessels



1 Vessel

MS “Seihav”
WELL-BOAT
Lerøy Seafood

“Meløyfjord”, “Voldnes”,
”Stokke Senior”, “Harto”
Purse Seiners



4 Vessels

WHY WE USE CPP - CONTROLLABLE PITCH PROPELLER

THE PATENTED STADT LEAN DRIVE COMBINES PITCH AND RPM-CONTROL

- Significantly improved overall efficiency at varying load and/or varying speed conditions
- Better manoeuvrability (acceleration, breaking, crash stop)
- Better performance at reversing and in DP
- Better operational conditions for gear, shaft, and bearings, especially at low speed
- Forgiving for design errors
- Each blade may be changed independently if damaged, at sea
- Future-proof with regard to changes of use of the vessel, slow steaming, extensions, etc.
- Possibility for full feathering position, which is saving fuel when only running one propeller



STADT HYBRID

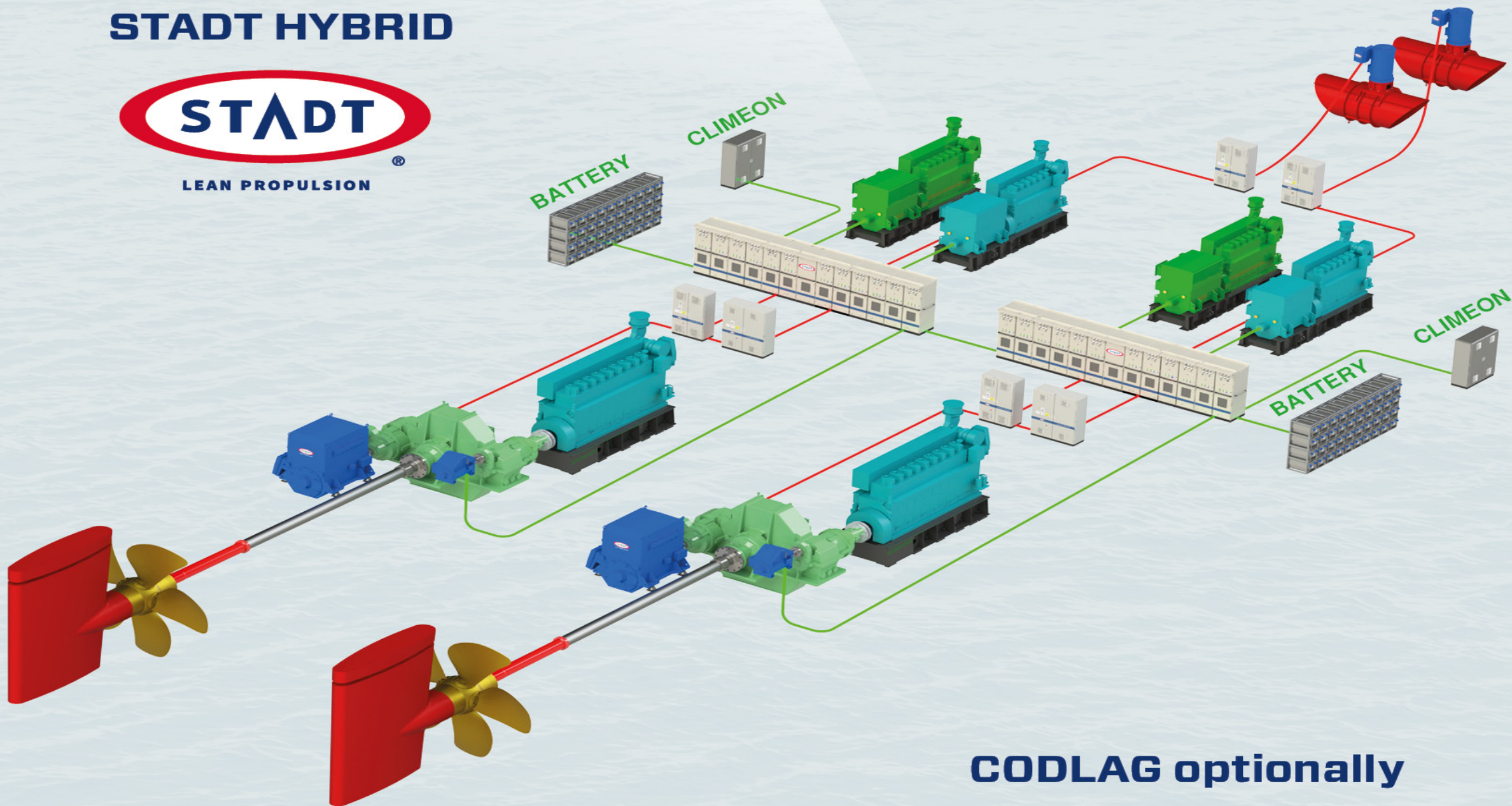

CODLAG optionally

STADT LEAN PROPULSION ARRANGEMENTS - IEP

SOME BASIC ARRANGEMENTS FOR FULL ELECTRIC PROPULSION, BASED ON DIESEL OR BIO FUELS



Twin screw PTI, CP

- 4 generators
- 4 electric motors
- 2 main switchboards

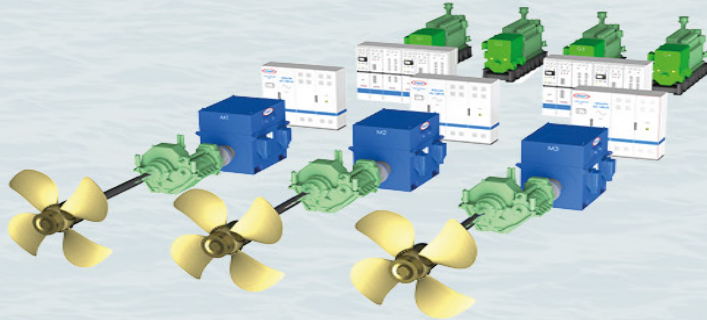

Triple screw, CP

- 4 generators
- 3 electric motors
- 2 main switchboards



Triple screw (2 Azipulls), CP

- 6 generators
- 3 electric motors
- 1 main switchboard with Bus-Tie

BATTERY OR FUEL CELL OPTIONS AVAILABLE IN ALL CONFIGURATIONS



Single screw, CP

- 2 diesel generators
- 1 gas turbine generator
- 2 electric motors
- 2 main switchboards



Single screw, CP

- 4 generators
- 2 electric motors
- 2 main switchboards

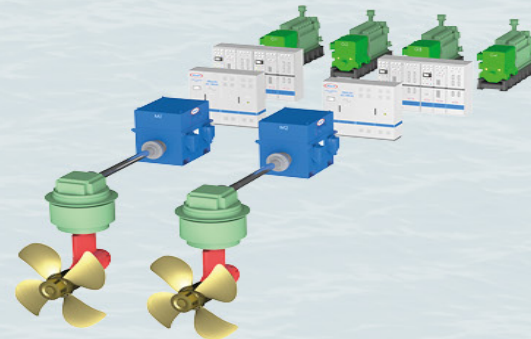

Twin screw (Azimuth or Voith), CP

- 4 generators
- 2 electric motors
- 2 main switchboards

CODLAG is also an option

LEAN BRINGS YOU

+ SAFETY & RELIABILITY
+ VERY LONG LIFETIME

+ STEALTH & HSE
+ MORE CARGO CAPACITY

+ LESS EMISSION AND FUEL
+ COST EFFICIENCY

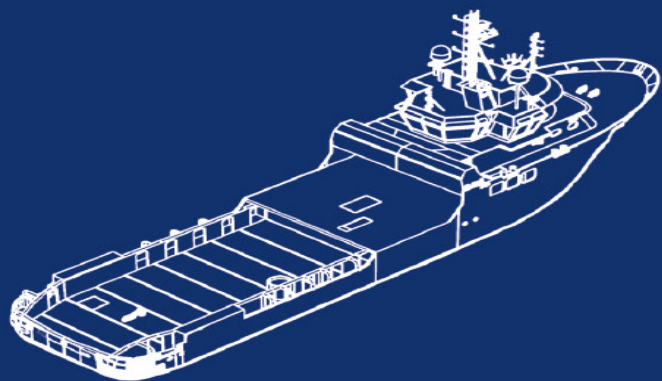

We are member of
**NORWEGIAN DEFENCE
AND SECURITY INDUSTRIES
ASSOCIATION**



LEAN PROPULSION

STADT AS
Moljevegen 50 | N-6083 Gjerdsvika | Norway
Tel.: +47 700 25 800 | www.stadt.no

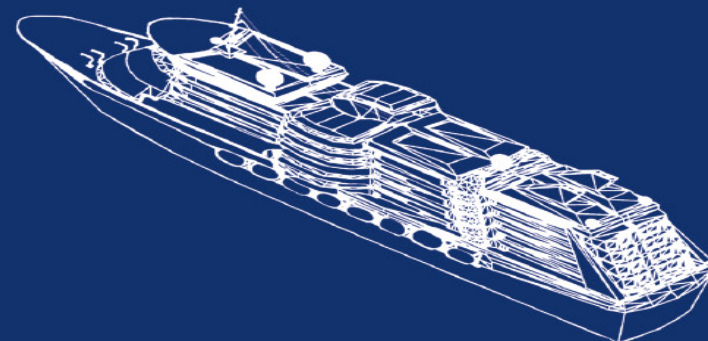
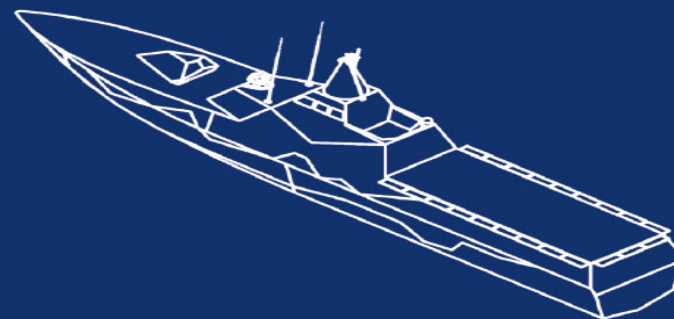

STADT LEAN PROPULSION

The Navy needs reliable vessels that are efficient to operate, year after year, in all seasons and weather conditions. Most importantly, the ship must have a reliable propulsion system with propellers and power systems that never fail. One that enables them to operate safely anywhere on the planet. As a vendor of conventional PWM propulsion systems for many years, we asked the question: “Can a new way of thinking also give us a new generation of naval propulsion systems that are prepared for tomorrow’s environmental challenges” ?

STADT has taken these challenges seriously, when developing the STADT LEAN DRIVE, based on a completely different architecture – a truly revolutionary design.

A lean propulsion system that is amazingly reliable, and also reduces service costs, weight, fuel, emission and waste, while freeing up space .

A sophisticated and silent system with STEALTH performance, extremely long lifetime, and excellent manoeuvrability.

Designed to meet MIL-STD-901 requirements.

The new drive technology has been awarded several times for its unique characteristics, and many ships are now sailing with the Lean Drive technology all over the world.



Hallvard Slettevoll

Director , CEO